

DS-16RP030 DC PLANETARY GEAR MOTOR

Main Voltage : 3VDC、6VDC、12VDC

Typical Applications :

Optical instrument, Surveillance cameras, Automated energy efficiency, Water saving equipment, IC water card, Toys and gifts, Office equipment, Household appliance, automation equipment



APPEARANCE SIZE

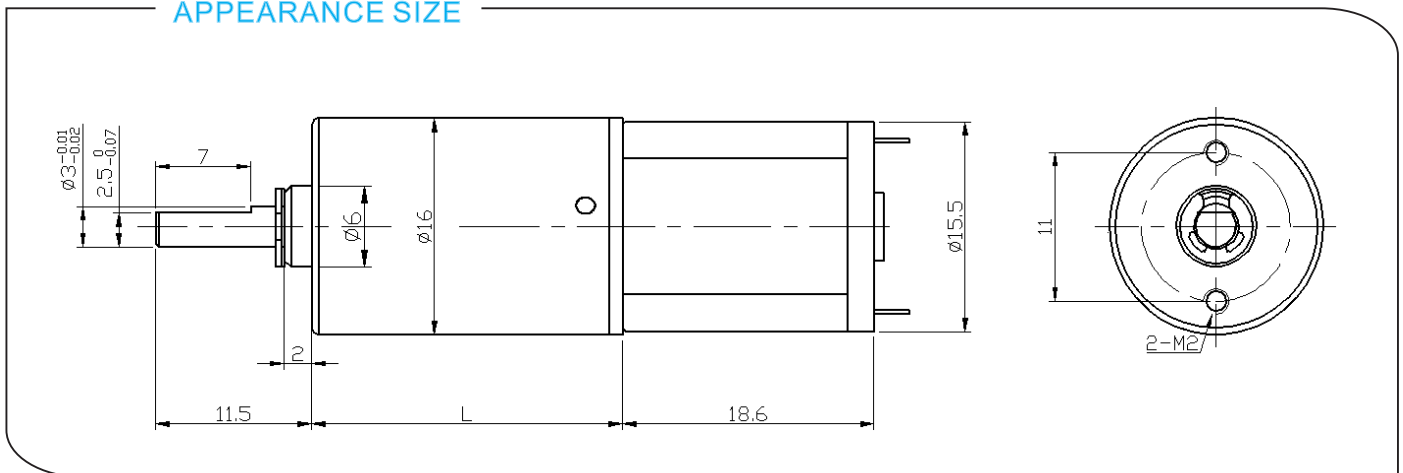

Gearbox Data:

Number of stages	1	2	3	4	5
Reduction ratio	4、4.75	16、19、22.5	64、76 90、107	256、304、361 428、509	1024、1216、1444 1714、2036、2418
Gearbox length "L"mm	12.2	15.8	19.4	23	26.6
Breaking torque(kgf.cm)	2	3	4	5	5
Gearbox efficiency	90%	81%	73%	65%	59%

Driving Motor Data:

Motor model	Rated Volt.	No load		Load				Stall	
		Current	Speed	Current	Speed	Torque	Output power	Torque	Current
		V	mA	r/min	mA	r/min	gf.cm	W	gf.cm
DS-030-003-8000	3	≤55	8000	≤250	6000	4	0.2	≥16	≥500
DS-030-003-10500	3	≤80	10500	≤300	7200	5	0.4	≥20	≥750
DS-030-006-8000	6	≤30	8000	≤120	5000	4	0.2	≥16	≥150
DS-030-006-10500	6	≤40	10500	≤160	7000	5	0.4	≥20	≥400

Remark:

Gear Motor Torque=Driving motor torque*Reduction ratio*Gearbox efficiency;
Gear Motor Speed=Driving motor speed/Reduction ratio

Motor detailed config can be customized according to customer's requests, like voltage,speed,as well as shaft length and shape...

Welcome OEM or ODM projects